



SLICER / MIXER Heavy-Duty Stands

Models: RA35-ES16-FL4 RA35-ES24-FL4

Design Features

- A combination of aluminum and stainless steel makes this slicer/mixer stand especially useful in institutional food-service applications
- Dual purpose stand serves as a work counter while providing a covered storage area
- Stainless steel top is provided with a marine edge to assist in preventing any spillage from reaching the floor
- Selective spacing on 1½" or 1" centers
- Four floor locks guarantee stability during slicing or other rigorous usage



Quality Construction

- Aluminum construction with marine edged stainless steel work top
- Interlocking extruded panels form easy to clean side walls that support 18" x 26" pans on 1½" centers
- Top frame consists of 1½" square tube heliarc welded at corners
- One piece .190 aluminum base
- 1½" x 1½" angle uprights are welded to .190 base and top frame
- 5" heavy-duty plate-type neoprene casters are bolted to base

Options & Accessories

- Corner bumpers
- Full perimeter bumper
- Vertical pan stop
- 5" polyurethane casters

Warranty & Certifications

Parts and Service Warranty

- Protected by BevLes 2 year parts and 1 year service warranty

Certified by the following:



Mailing: 729 Third Ave., Dallas, TX 75226 • Shipping: 1938 Wyott Dr., Cheyenne, WY 82007
(800) 441-1601 • Fax: (214) 565-0976 • www.bevles.com • sales@bevles.com



SLICER / MIXER Heavy-Duty Stands

Models: RA35-ES16-FL4 RA35-ES24-FL4

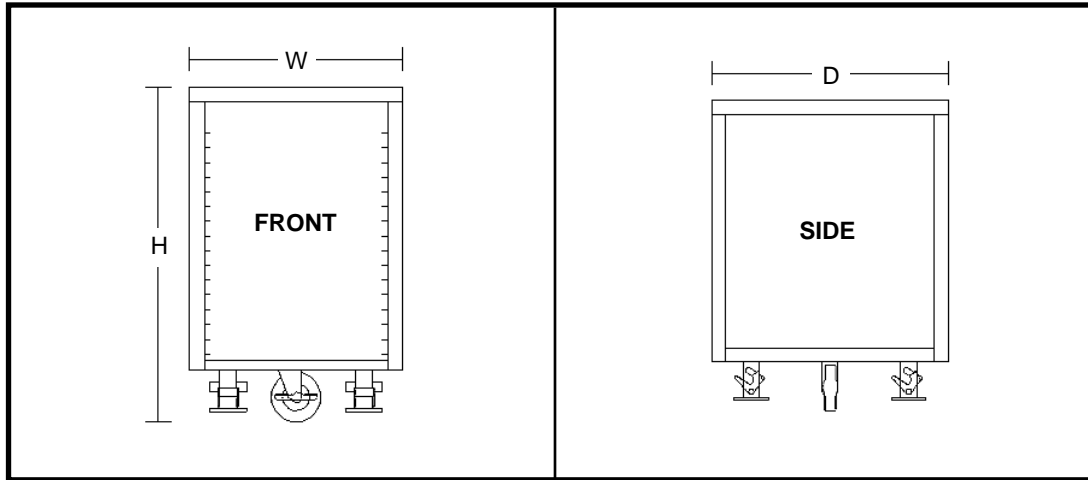

Model	Capacity			Dimensions			Ship Wt.	Act. Wt.
	18x26	12x20	SPC'G	H	W	D		
RA35-ES16-FL4	16	---	1½"	35" (88.9 cm)	21.5" (54.6 cm)	26" (66 cm)	85 lbs (38.6 kg)	70 lbs (31.8 kg)
RA35-ES24-FL4	24	---	1"	35" (88.9 cm)	21.5" (54.6 cm)	26" (66 cm)	89 lbs (40.4 kg)	74 lbs (33.6 kg)

Construction

- Top frame consists of durable 1½" square tube heliarc welded at all corners
- Base is .190 aluminum
- Uprights are 1½" x 1½" extruded angle welded to base and top frame
- Sides consist of interlocking extruded panels
- Work top is 20 ga. stainless steel with marine edge

Pan Supports

- Extruded panels with 9/16" wide ledges on 1½" centers to lip support 18" x 26" pans

Casters

- Heavy-duty plate-type casters, all swivel with neoprene wheels
- Four 5" floor locks

Shipping

- Freight Class: 250
- FOB: Cheyenne, WY 82007

* Note: Modifications involving casters or legs may affect height of equipment. Specifications subject to change without notice.



Mailing: 729 Third Ave., Dallas, TX 75226 • Shipping: 1938 Wyatt Dr., Cheyenne, WY 82007
(800) 441-1601 • Fax: (214) 565-0976 • www.bevles.com • sales@bevles.com

6/20/05
#B510