



TEMPER SELECT ALUMINUM HEATED HOLDING SYSTEMS

Job _____ Item # _____

HEATED HOLDING CABINETS

- Model HTST74W12A** Full-size Universal
- Model HTST44W6A** Half-size Universal



Model HTST74W12A
with standard, reversible doors

STANDARD FEATURES

- All aluminum construction with welded aluminum base
- Fully insulated throughout
- Side air tunnel systems circulate air evenly
- Top-mounted convection heat & humidity system maintains even heat, quick pre-heat and rapid recovery
- Accurate & reliable solid-state controls
- Easy-to-clean radius corners
- Removable top water pan for additional humidity
- Heavy-duty plate-type casters with 5" hard rubber wheels & front breaks
- Field-reversible doors with self-closing lift-off hinges, magnetic latches & door gaskets, cool-touch handle & turn knob lock
- Dutch doors on full-size models
- Recessed stainless steel side-mounted pull grips
- 120v, 15a, 1ph, 50/60hz
- 120v, 20a, 1ph, 50/60hz
- 208v, 15a, 1ph, 50/60hz
- 240v, 15a, 1ph, 50/60hz
- Limited 2 year parts - 1 year labor warranty

SPECIFICATIONS

Temper Select cabinets are constructed of aluminum inside and out with a welded aluminum base and feature fully insulated top, sides, base and doors.

Temper Select cabinets are available in Full-Size or Half-Size models. Half-Size cabinets may be ordered stacked to provide two separate, unique environments.

Top mounted convection heating and humidity system produces uniform temperature and humidity throughout by a side air tunnel system even when the door is open.

Temperatures range from 70°-215°F (21°-102°C) and features include solid state controls with digital display option.

Standard features include field-reversible doors, lift-off, self-closing hinges, magnetic door gaskets and latch, cool-touch handles, radius corners, front end pull grips, heavy-duty 5" plate-type casters and removable water pan for added moisture.

Universal models feature adjustable slide spacing on 1 1/2" increments (38mm) and accommodate 18"x26" pans and/or 18"x13" pans and/or 12"x20" pans.

Limited 2 year parts, 1 year labor warranty.

OPTIONS & ACCESSORIES

- Full perimeter bumper and corner bumpers
- Additional universal shelves
- Left-hand hinged doors
- Pass-through design
- Doors with tempered glass windows
- Stainless steel cord wrap
- Key lock hatch
- Digital temperature display — model HTSD
- Transport handles
- 5" polyurethane casters
- All stainless models available
- 1/2-Size cabinets may be ordered stacked

CERTIFICATIONS



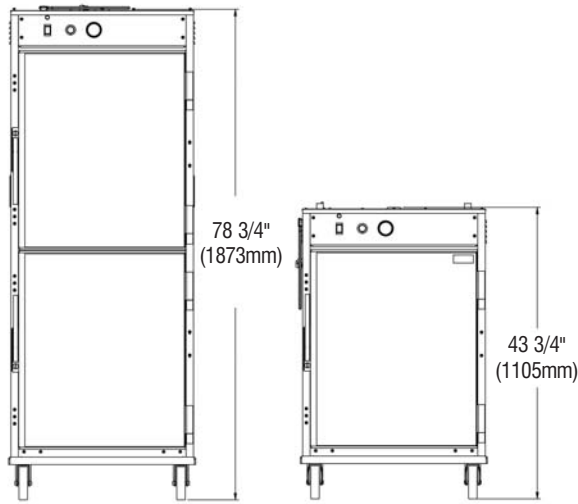

Full Size

Half Size

FRONT VIEW

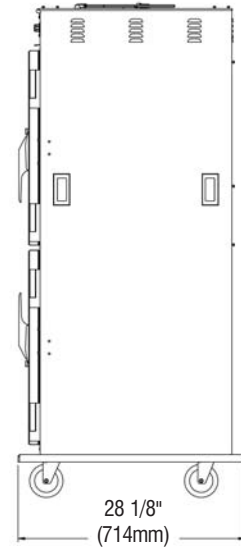

Full Size

SIDE VIEW

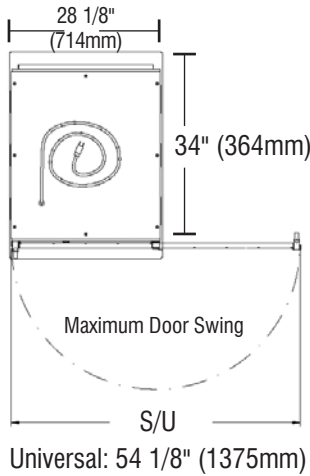

TOP VIEW

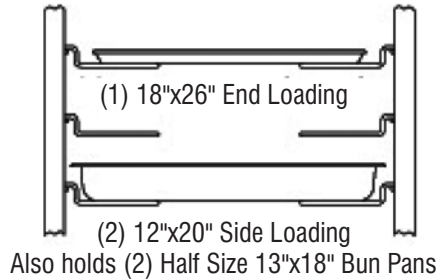

LOADING CAPACITY

ALL DIMENSIONS NOMINAL

Continuous product improvement is a policy of BKI/BEVLES. Therefore, specifications and design are subject to change without notice.

SHIPPING INFORMATION										
Model	Carton Size		Carton Dimensions				Shipping Weight			
	Cubic Feet	Cubic Meters	Width Inches	mm	Depth Inches	mm	Height Inches	mm	Lbs	Kilos
HTST74W12A	52	1.5	32	813	36	914	73.25	1860	345	157
HTST44W6A	33	1	32	813	34.5	876	44	1120	229	104

CAPACITY				
Model	Slide Spacing	# of Positions	Type	# of Shelves Provided
HTST74W12A	1 1/2"	34	Adjustable	*12
HTST44W6A	1 1/2"	16	Adjustable	*6

** Additional Shelves Available*

POWER SUPPLY					
All Models	Volts	Watts	Amps	Electrical Service	Phase
Standard	120	1274	10.6	15A	50/60
Standard - HW	120	1824	15.2	20A	50/60
Optional	208	1581	7.6	15A	50/60
Optional	240	2092	8.7	15A	50/60

MINIMUM CLEARANCES		
	Inches	mm
Right	0	0
Left	0	0
Rear	0	0

