



HEATED HOLDING CABINETS

Non-Insulated Economy Series

Models: □ HC70-ES32 □ HC70-MP12

Design Features

- Solid state temperature control with digital display
- Temperature adjustable to 200°F (93°C)
- Dual heating elements with 2000 total watts
- "Cast in" 5 quart (4.7 liter) water reservoir prevents element burnout
- Dutch doors with positive-closing latch
- "MP" model provided with adjustable heavy-duty extruded universal pan supports that accept 12" x 20" and 18" x 26" pans
- "ES" model features louvered pan supports for lip loading 18" x 26" pans
- Heavy-duty sealed power switch protects from water, grease, and dirt



Quality Construction

- Aluminum construction
- Bottom mounted convection heat and humidity system easily removable for cleaning or service
- Fully insulated doors
- Heavy-duty stainless steel hinges, positive closing latch and magnetic door gasket(s)
- Heavy-duty plate-type casters with 5" hard neoprene wheels, front two with brakes
- One piece, formed base with welded corners

Options & Accessories

- Corner bumpers
- Perimeter bumper
- Left or right-hand door hinging
- Choice of 4" or 5" casters
- Additional extruded universal pan supports

Warranty & Certifications

Parts and Service Warranty

- Protected by BevLes 2 year parts and 1 year service warranty

Certified by the following:



Mailing: 729 Third Ave., Dallas, TX 75226 • Shipping: 1938 Wyott Dr., Cheyenne, WY 82007
(800) 441-1601 • Fax: (214) 565-0976 • www.bevles.com • sales@bevles.com



HEATED HOLDING CABINETS

Non-Insulated Economy Series

Models: HC70-ES32 HC70-MP12

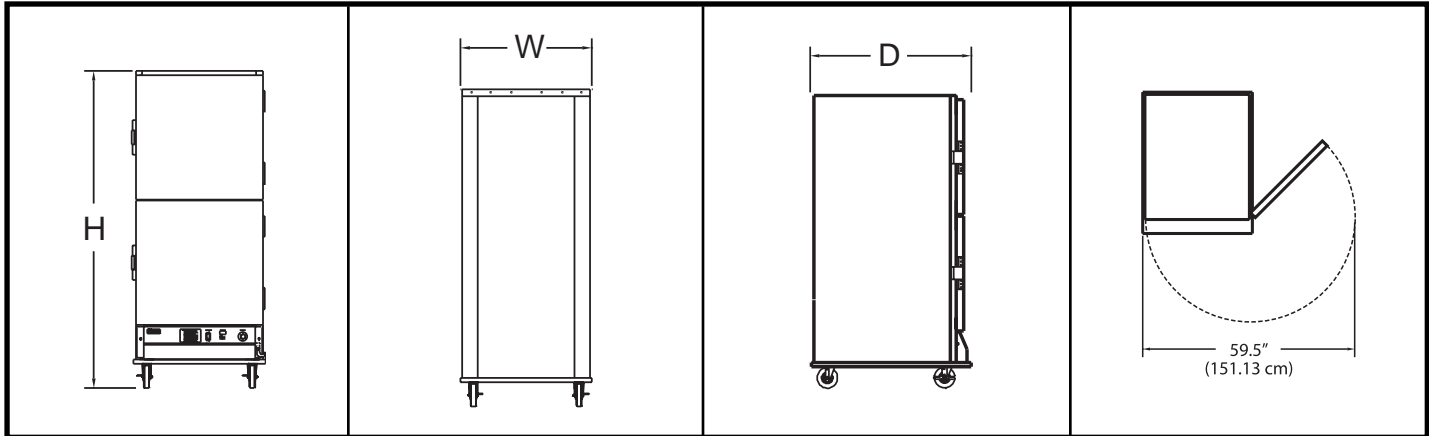

Model	Capacity			Dimensions			Ship Wt.	Act. Wt.	
	18x26	12x20	SPC*G*	H	W	D			
Standard Size									
HC70-ES32	32	--	1½"	72" (182.9 cm)	31" (78.7 cm)	35" (88.9 cm)	210 lbs (95.3 kg)	175 lbs (79.4 kg)	
Universal Size									
HC70-MP12	12	24	4½"	72" (182.9 cm)	31" (78.7 cm)	35" (88.9 cm)	220 lbs (99.8 kg)	185 lbs (83.9 kg)	

Electrical	Voltage	Watts	Amps	Electric Service	Phase	Hertz	Clearances
All Models	120V	2000	16	20A Dedicated Circuit	1	50/60	Zero Clearance Cabinet

*Adjustable on 1 1/2" centers

Construction:

- **Body:** .063 aluminum
- **Exterior Doors:** .063 aluminum
- **Interior Doors:** 22 ga. auto-brite stainless
- **Door Insulation:** 1.5" fiberglass (5.7 rating of .26K per inch)
- **Door Latch and Hinges:** Patented positive action latch with heavy-duty stainless steel hinges
- **Door Gasket(s):** Magnetic, NSF approved
- **Base:** .125 aluminum, welded at corners
- **Cord Guide/Protector:** Unique cord guide provides safe and easy routing to rear of cabinet

Pan Support Assembly:

- MP model supplied with 12 pairs of heavy-duty extruded universal pan supports adjustable on 1 1/2" centers (pans are bottom supported)
- ES model has aluminum louvered pan supports on 1 1/2" centers for 18" x 26" pans (pans are lip supported)

Casters:

- Heavy-duty plate type casters, with 5" hard neoprene wheels; all swivel, with wheel brakes on front two casters

Heating Module and Controls:

- Bottom mounted heating unit with a one (1) piece modular drop-in design blower assembly
- Air heating element rated at 1600W, 120V
- Humidity heating element rated at 400W, 120V
- 5 quart (4.7 liter) cast water reservoir
- Easy to operate, user friendly microprocessor controls
- All controls are visible and operable from exterior of cabinet
- Maintains a uniform air temperature to 200°F (93°C)

Electrical:

- 120V-20A, 1PH electrical service
- Optional 208/240V-20A, 1PH electrical service
- **Switch:** Sealed custom heavy-duty 20 Amp
- **Cord and Plug:** 8' cord with 20A molded plug (NEMA 5-20P); 208/240V models provided with cord only

Shipping:

- Freight Class: 85
- FOB: Cheyenne, WY 82007

* Note: Modifications involving casters or legs may affect height of equipment. Specifications subject to change without notice.



Mailing: 729 Third Ave., Dallas, TX 75226 • Shipping: 1938 Wyatt Dr., Cheyenne, WY 82007
 (800) 441-1601 • Fax: (214) 565-0976 • www.bevles.com • sales@bevles.com

4/20/05
 #B107