



Fresh ideas in foodservice equipment

Donut Fryers

Model: DNF, DNF-F

Large Volume Electric Donut Fryer with optional Filter



Improve productivity and profits with BKI's donut fryer. This fryer is sure to increase volume with minimum labor and space. Uniform cooking and heating cooks two dozen donuts in only 90 seconds for high volume production. Highest quality construction stands up to heavy use. Exceptional pricing makes the BKI donut fryer the profitable, value choice for any retail or catering business.

Standard Features:

- 24 donuts, 70 lb (31.8 kg) Oil Capacity
- Hinged drain board that can be mounted on left or right side
- 5" Casters for easy mobility
- External Material (18 gauge, 304 Stainless Steel)

(BKI's DNF-F Electric Donut Fryer shown underneath a FH-28D Ventless Hood)

Agency Approvals:



BKI North America
PO Box 80400
Simpsonville, SC 29680-0400 USA
Telephone: (864) 963-3471
Toll Free: (800) 927-6887

BKI Europe
Theale Technology Centre
Station Road • Theale
Reading • West Berkshire • RG7 4AA
Telephone: 0870 9904242 • Fax: 0870 9904243



Donut Fryers (DNF, DNF-F)

Equipment Dimensions:

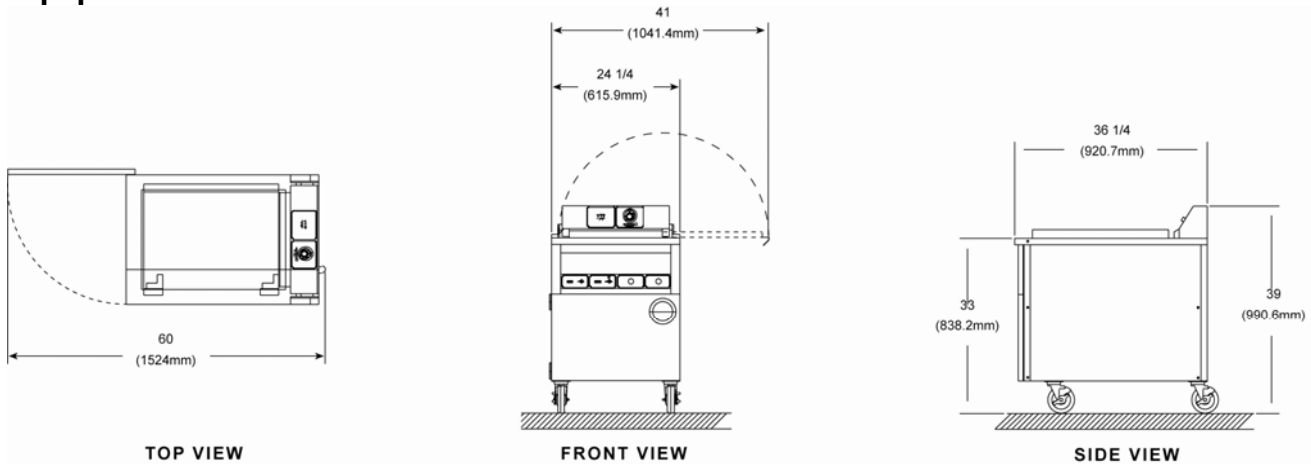

DNF is depicted above but the dimensions shown apply to all models.

Mechanical Specifications:

Dimension	Uncrated	Crated
Height	33" (838.2 mm)	57" (1450.4 mm)
Width	24.25" (616 mm)	27" (687 mm)
Depth	36.25" (920.7 mm)	42" (1068.7 mm)
Floor Space	6.2 sq. ft (.6 sq. m)	7.9 sq. ft (.73 sq. m)
Weight	300 lb. (136.1 kg)	315 lb. (142.9 kg)

Electrical Options:

Volts	Amps	Breaker	KW	Wires	Phase
220/380/50Hz	14.5	30	9.6	4	3
240	35.6	50	8.6	2	1
240/415	38.8	45	9.3	2	1
200/346	43.4	50	8.7	2	1
220/380	47	60	10.4	2	1

Accessories (Optional)

	DNF	DNF-F
FKF Remote Filter with small vat (231000)	✓	
FKF Remote Filter with large vat (231001)	✓	
FKF-H Remote Filter with Heater (231100)	✓	
FH-28D Ventless Hood (371010)	✓	✓
BG-2 Donut Glazer w/casters, scissor ladle (710001)	✓	✓
Filter Rinse Hose assembly (SB2332)	✓	✓
Wooden flipstick (D0012)	✓	✓
Fry screen, 17" x 25" (R0012)	✓	✓
Submerger Screen (R0019)	✓	✓
Lift for use with fry screens (R0020)	✓	✓
Wire Racks for BG-2 Glazer (R0021)	✓	✓
Scissor ladle (SB7103)	✓	✓
13" insulating mitts (G0052)	✓	✓
Filter Paper (F10007)		✓

Model Features/Options

	DNF	DNF-F
Shortening Filter System		✓
Left or right side drain board mounting	✓	✓

BKI North America
 PO Box 80400
 Simpsonville, SC 29680-0400 USA
 Telephone: (864) 963-3471
 Toll Free: (800) 927-6887

BKI Europe
 Theale Technology Centre
 Station Road • Theale
 Reading • West Berkshire • RG7 4AA
 Telephone: 0870 9904242 • Fax: 0870 9904243

