



Fresh ideas in foodservice equipment



BT-24 Breeding Table shown above



BT-24M Breeding Table shown above

Agency Approvals:



Breeding Table

Model: BT-24, BT-24M

Compact, portable work table for breading and preparing product for frying

Simplicity in design, quality that is affordable - BKI's breeding tables are the perfect companion for BKI's full line of fryers. The tables are compact and portable for breading and preparing product for frying. Our breeding system is designed to produce a consistent product look while reducing breading costs. An easily operated hand sifter separates the doughballs promoting consistency in the sifted breading. Our equipment is constructed of top quality stainless steel for years of dependable operation and backed by over 50 years of foodservice manufacturing excellence.

Standard Features:

- Stainless steel construction, non-magnetic, non-corrosive
- 4-locking casters
- Sifter drawer with lower receiving pan
- Lug shelf for raw chicken
- UL Sanitation-listed

BKI North America
PO Box 80400
Simpsonville, SC 29680-0400 USA
Telephone: (864) 963-3471
Toll Free: (800) 927-6887

BKI Europe
Theale Technology Centre
Station Road • Theale
Reading • West Berkshire • RG7 4AA
Telephone: 0870 9904242 • Fax: 0870 9904243



Breading Table (BT-24, BT-24M)

Equipment Dimensions:

BT-24

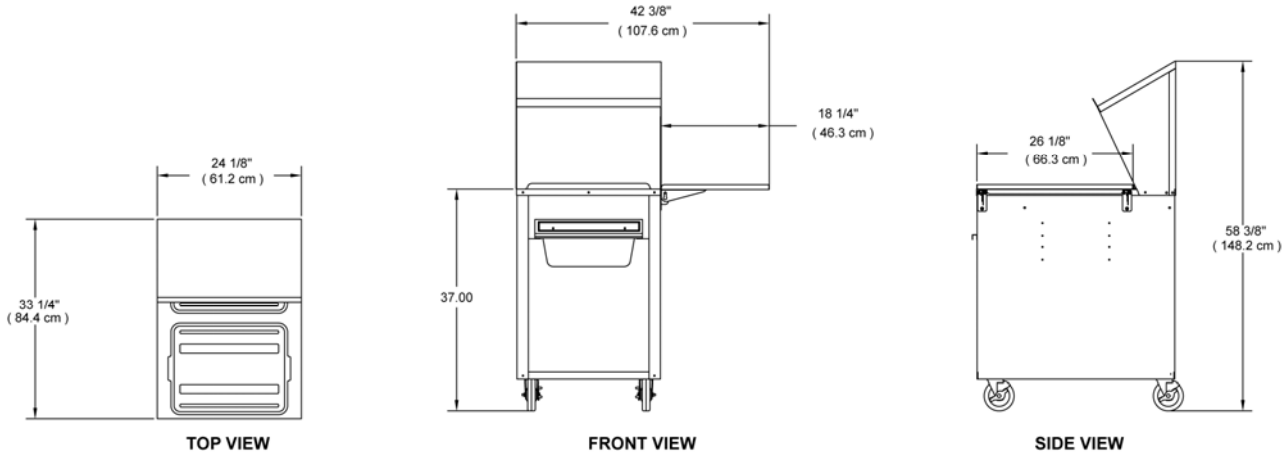

BT-24M

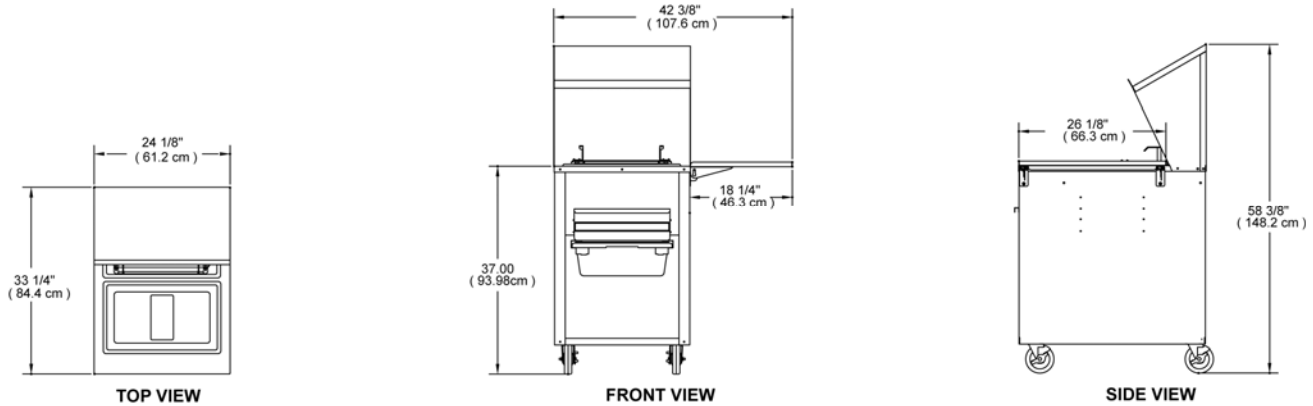

Mechanical Specifications:

Dimension	Uncrated		Crated	
	BT-24	BT-24M	BT-24	BT-24M
Height	58 3/8" (1486 mm)	58 3/8" (1486 mm)	35.5" (903.3 mm)	35.5" (903.3 mm)
Width	24 1/8" (618.3 mm)	24 1/8" (618.3 mm)	28.5" (725.2 mm)	28.5" (725.2 mm)
Depth	33 1/4" (847.3 mm)	33 1/4" (847.3 mm)	46" (1170.5 mm)	46" (1170.5 mm)
Floor Space	5.6 sq. ft. (.52 sq. m)	5.6 sq. ft. (.52 sq. m)	9.1 sq. ft. (.85 sq. m)	9.1 sq. ft. (.85 sq. m)
Weight	85 lbs. (38.6 Kg)	150 lbs (68 Kg)	100 lbs. (45.4 Kg)	166 lbs. (75.3 Kg)

Model Features

	BT-24	BT-24M
Spring loaded marinade basket hinged to deliver chicken pieces into the breading lug		✓
Metal breading lug and marinade pan		✓
Removable and reversible side tray		✓
Removable and reversible side shelf	✓	
2- Plastic Pans (15" x 20" x 5", 38.1cm x 50.8cm x 12.7cm)	✓	

Model Options

	BT-24	BT-24M
Left or right side mounted hinged shelf for 18" x 26" pan	✓	
Left or right side mounted hinged tray		✓

BKI North America
 PO Box 80400
 Simpsonville, SC 29680-0400 USA
 Telephone: (864) 963-3471
 Toll Free: (800) 927-6887

BKI Europe
 Theale Technology Centre
 Station Road • Theale
 Reading • West Berkshire • RG7 4AA
 Telephone: 0870 9904242 • Fax: 0870 9904243

