

# DSY-1100

# Digital Scale

A rugged and sensitive scale to suit multiple applications  
A broad selection of capacities and divisions  
Over 5000 hours of battery life  
Legal for trade! C. of C. #95-065  
U.S.D.A accepted!

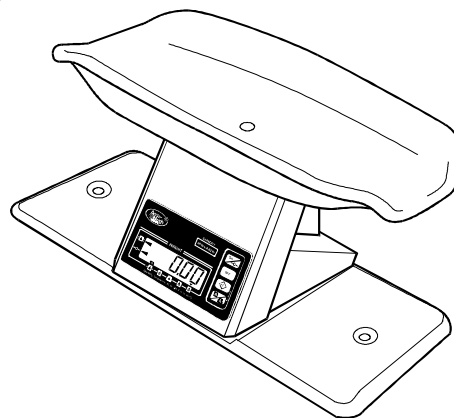
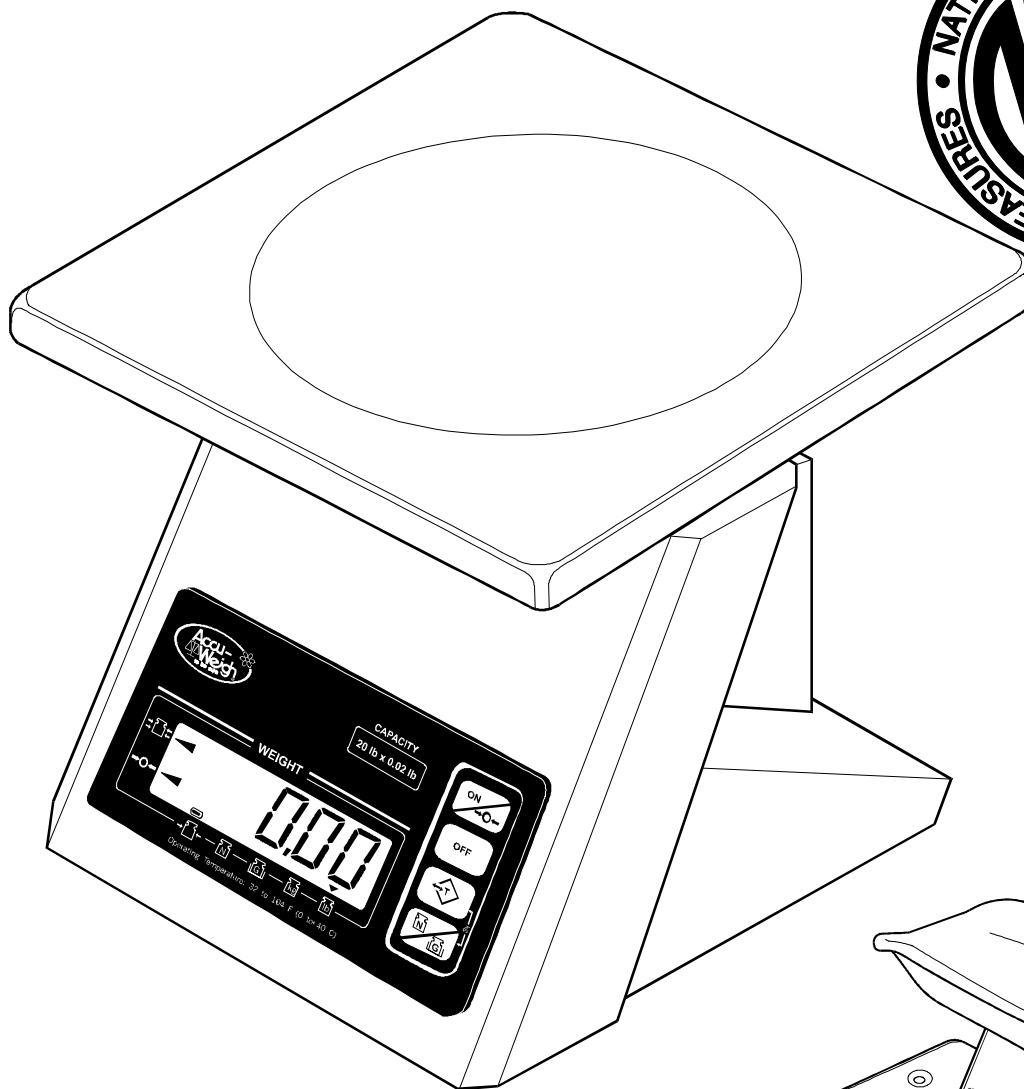

## Vibrating wire

The DSY-1100 series digital scales feature an exclusive, amazingly accurate "vibrating wire" load cell system. This technological breakthrough has resulted in a series of rugged yet sensitive scales to suit a broad range of applications, and it is legal for trade.

## Fast and easy to use

The slanted display is easy to read whether sitting or standing. Weights are displayed within a fraction of a second, in large .9" (23mm) digits that are bright and easily readable.

## Features

The DSY-1100 series scales are designed with micro-processor

based circuitry to provide an array of valuable electronic functions, all standard, such as:

- 5000 hr. battery life
- Center of zero indication
- Zero reset key
- Zero tracking
- Automatic display check of all digital segments
- Unit of weight selection
- Gross/net weighing modes
- Selectable Auto-off function to prolong battery life
- Low battery indication
- Overload and underload display warnings
- Hold indication
- Stable indication
- USDA accepted

## Sanitary

The shatterproof ABS plastic housing wipes clean with a damp cloth. The large 9" x 9" stainless steel platform is readily removable for thorough cleaning. The entire housing and display panel are splash-proof.

## Multiple applications

The DSY-1100 series scales are all lb and kg, or oz and kg, selectable and are configured in 15 different capacities and divisions to best suit your needs. Choose from several receptacle options, including; 10 inch pan, 5 or 18 quart bowl or a cradle and table mount for baby weighing in hospital wards, also perfect for weighing slippery fish that won't hold still.

## Specifications

Model	Capacity	Model	Capacity
DSY-1100-2	2lb x 0.002lb 1kg x 0.001kg	DSY-1100-2C	40 oz x 0.05 oz 1 kg x 0.001 kg
DSY-1100-5	5lb x 0.005lb 2kg x 0.002kg	DSY-1100-5C	80 oz x 0.1 oz 2 kg x 0.002 kg
DSY-1100-10	10lb x 0.01lb 5kg x 0.005kg	DSY-1100-10C	160oz x 0.2 oz 5kg x 0.005 kg
DSY-1100-20	20lb x 0.02lb 10kg x 0.01kg	DSY-1100-20C	400ozx0.5 oz 10kg x 0.01 kg
DSY-1100-50	50lb x 0.05lb 20kg x 0.02kg	DSY-1100-50C	800oz x 1 oz 20 kg x 0.02 kg
<b>NOT LEGAL FOR TRADE</b>			
DSY-1100-2Z	2 lb x 0.05 oz 1 kg x 0.001 kg		
DSY-1100-5Z	5 lb x 0.1 oz 2 kg x 0.002 kg		
DSY-1100-10Z	10 lb x 0.2 oz 5 kg x 0.005 oz		
DSY-1100-25Z	25 lb x 0.5 oz 10 kg x 0.01 kg		
DSY-1100-50Z	50 lb x 1 oz 20 kg x 0.02 kg		

**Display 0.8" (20mm) LCD**  
**Overload Condition Mechanical stops**  
**Display warning**  
**Tare Range Full Scale**  
**Zero Tracking Range Full Scale**  
**Power 4 "D"-cells or optional AC adapter**  
**Net Weight 5.5 lb**  
**Dimensions 9"(W) x 8.25"(H) x 9" (D)**

YAMATO CORPORATION  
 1775 S. Murray Blvd.  
 Colorado Springs, CO 80916 USA  
 Tel (719) 591-1500 Fax (719) 591-1045

YAMATO TECH CORPORATION  
 #112-19425 Langley By-Pass  
 Surrey, B.C. V3S 6K1 Canada  
 Tel (604) 533-2338 Fax (604) 533-0827