

A rugged, accurate, multi-purpose scale...

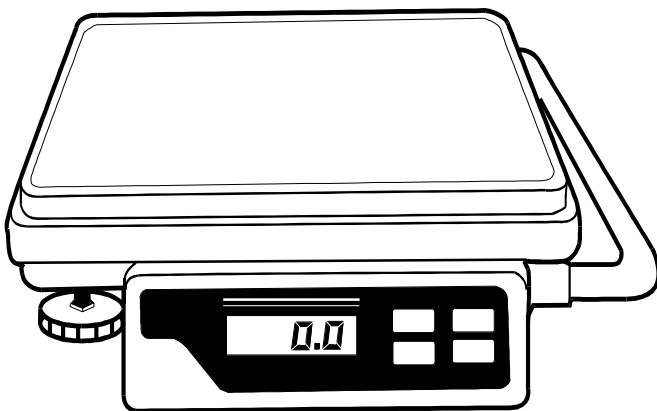
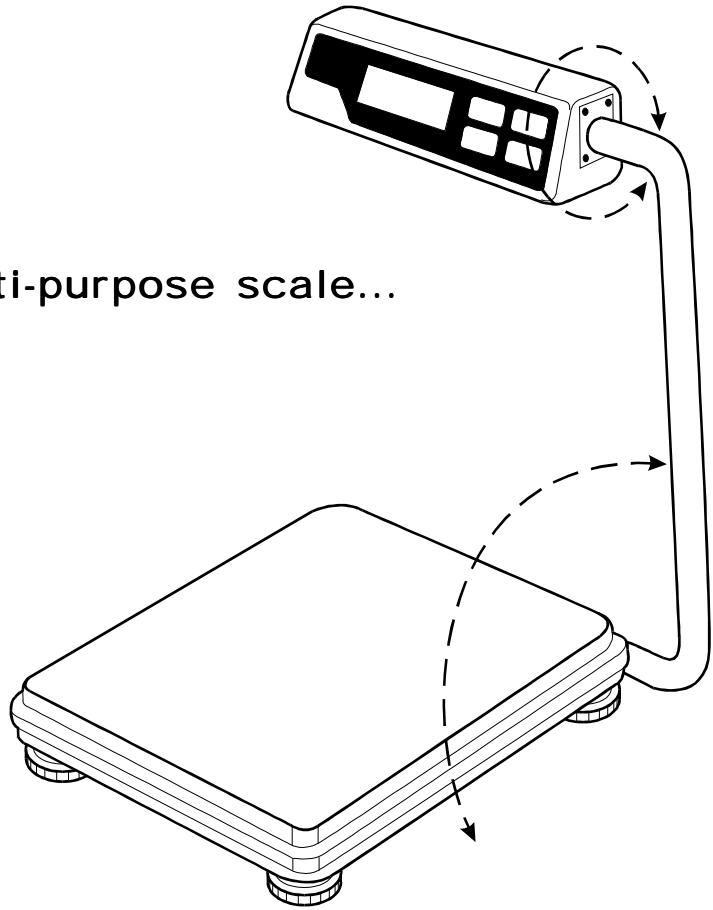

...built to last!

DP-8100

Digital Platform Scales

A Simple , basic, all around scale, built like a rock

Quality construction

The DP-8100 incorporates the latest in vibrating wire single load cell technology. This design eliminates the need for pivots, bearings, levers and flexures. A rugged, high performance, factory calibrated cell is at the "heart" of the system. The unitized body combined with the tubular steel construction provides a distortion-free base equipment with two overload stops. Under the platform, special shock absorbent pads give additional protection to the load cell.

Flexibility

The DP-8100 base is stainless steel, and USDA accepted. It is equipped with sturdy leveling legs to insure firm support of the base for maximum weighing accuracy.

Easy to use

The Large 0.8" (20 mm) liquid crystal display is bright and easily readable. The display comes mounted on a 23" (585 mm) chrome plated swivel column for convenient placement. For easy transportation, the column quickly converts to a carrying handle.

Battery Operation

Over 1000 hours of operation under typical usage. An Optional AC adapter is available.

Service and maintenance

Service and maintenance are available throughout hundreds of Yamato dealers in the United States and Canada.

All dimensions are approximate. Dimensions are given in inches (millimeters.)

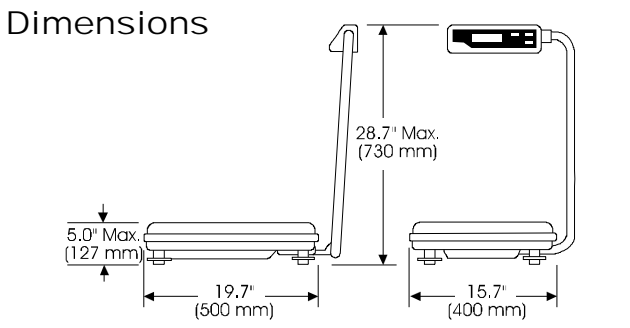

Model	DPI-8100	
Capacities	DP-8100	150 lb x 0.1 lb / 300 lb x 0.2 lb 75 kg x 0.05 kg / 150 kg x 0.1 kg
	DP-8100z	150 lb x 2 oz / 300 lb x 4 oz 75 kg x 0.05 kg / 150 kg x 0.1 kg
Weighing System	Strain Gauge Load Cell	
Taring range	Full Scale	
Indicator	4.1" W x 0.8" H (112 mm W x 20 mm H)	
Display units	Liquid Crystal Display: 5 Digits plus indicators	
Platform Dimensions	Decimal lb / kg	
Power source	4 C Size Batteries or AC Adapter	
Operating temperature range	32°F ~ 104°F (0 C ~ 40 C)	
Shipping Weight	43 lb (20kg)	

Fully electronic system

The weight indication is microprocessor based. The circuitry provides an array of valuable electronic functions, all standard, such as:

- lb/kg change over
- Net/gross change over
- Full scale semiautomatic tare
- Zero tracking
- Zero reset
- Automatic display check
- Low battery indication
- Overload display warning

Limited warranty

Comprehensive one year limited warranty (subject to our standard terms and conditions) against defects in parts and workmanship under normal conditions of installation, maintenance and usage.

Yamato
www.YamatoCorp.com

YAMATO CORPORATION
1775 S. Murray Blvd.
Colorado Springs, CO 80916 USA
Tel (719) 591-1500 Fax (719) 591-1045

YAMATO TECH CORPORATION
#112-19425 Langley By-Pass
Surrey, B.C. V3S 6K1 Canada
Tel (604) 533-2338 Fax (604) 533-0827