



HALF-SIZE ELECTRIC CONVECTION OVENS

Job _____ Item # _____

ELECTRIC CONVECTION OVENS

- Model COH-ES Single
- Model COH-ED Double



Model COH-ES
shown with left hand hinge & right side controls

STANDARD FEATURES

- Energy efficient 9.5 KW per oven direct forced air heat system
- 208v or 220v-240v, 60hz or 50hz
- Electronic temperature control
- Double-pane thermal glass door window
- Oven lights
- 60-Minute continuous ring timer with manual shut-off
- 150°F (65°C) to 550°F (285°C) temperature range
- 1/4 HP air-cooled two-speed fan motor
- Cool down fan mode
- Elements-on and temperature-ready indicator lights
- Porcelain enamel oven interior
- 11-Position removable rack guides with 1 5/8" spacing
- 5 Heavy-duty, positive-stop, chrome-plated wire racks
- Stainless steel stainless front, top & sides
- Stainless steel, fully insulated hinged door
- Front mounted control panel for easy service access
- 1/8" Welded angle iron frame construction
- Heavy-duty industrial grade insulation in top, sides, back and doors
- One year limited parts & labor warranty

SPECIFICATIONS

Half-size electric, forced air, single and double stack convection type oven. Standard specifications include 9.5 KW per cavity and a patented two speed fan-within-a-fan enhanced air flow system powered by an energy efficient 1/4 HP two-speed fan motor.

Door interlock switch automatically turns the fan and heating elements off when the oven door is open. A manual rotary switch will turn the fan on when the door is open for quick cool-down. The 60-minute timer has a continuous ring with manual shut-off. An indicator light glows when the heating elements are on.

The oven interior measures 23" wide (584mm) by 20" high (508mm) by 15 5/8" deep (397mm). The cooking chamber is porcelain enamel over heavy gauge steel with removable 11-position rack guides with 1 5/8" spacing (41mm) and 5 heavy-duty adjustable chrome-plated racks.

The oven exterior measures 31" wide (787mm) by 27 1/2" deep (699mm) by 25" high (635mm). Front, top and sides and trim are constructed with stainless steel.

A single fully insulated stainless steel door with thermal pane window opens a full 180° and features a unique 23" opening wide mouth design for easy viewing and sideways loading of 1/2-size sheet pans.

Ovens may be ordered with left hand hinge and right side controls or right hand hinge and left side controls.

OPTIONS & ACCESSORIES

- Steam injection with front panel controls
- Computerized programmable controls with LED display.
- Stainless steel stand with or without casters
- Additional oven racks
- International voltages, 50hz
- Solid door
- Perforated rear panel
- Stacking kit

CERTIFICATIONS



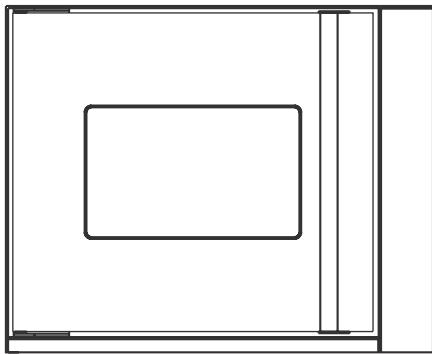

FRONT VIEW

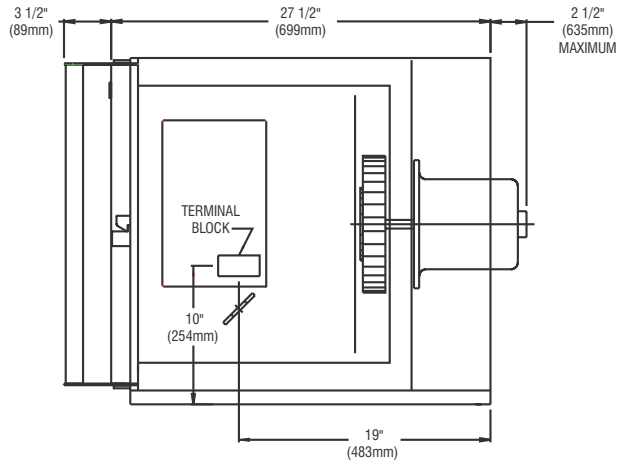

SIDE VIEW — Single Unit

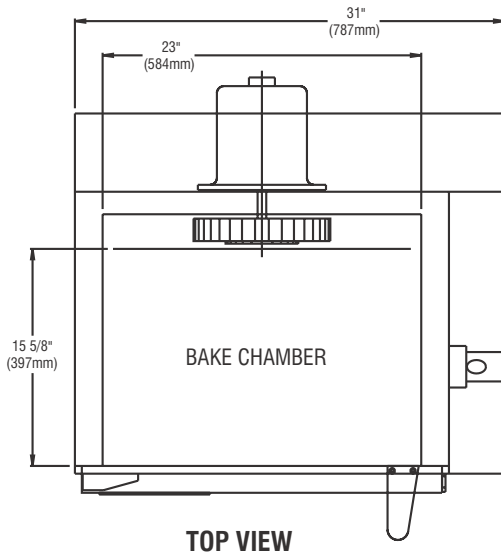

TOP VIEW

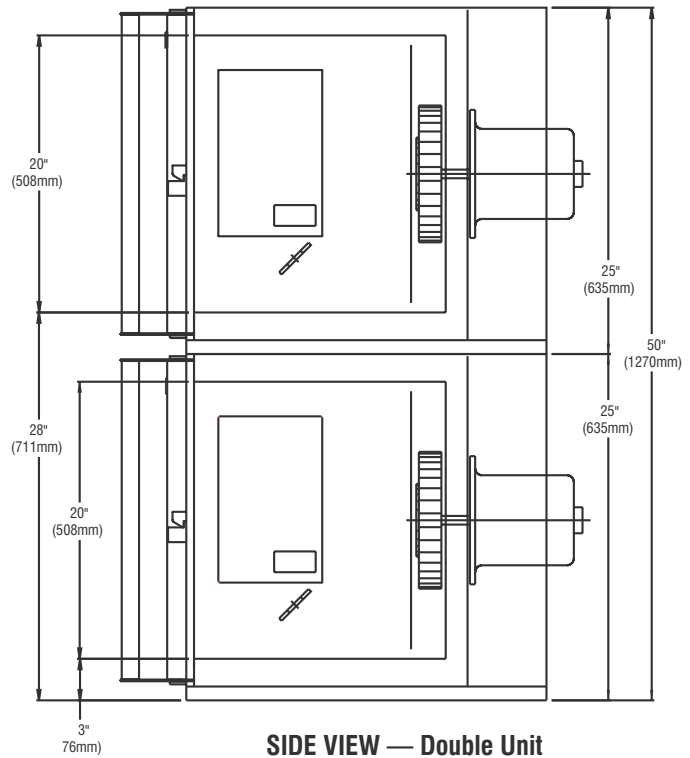

SIDE VIEW — Double Unit

ALL DIMENSIONS NOMINAL

Continuous product improvement is a policy of BKI. Therefore, specifications and design are subject to change without notice.

SHIPPING INFORMATION

Model	Shipping Weight		Carton Size		Carton Dimensions					
	Lbs.	Kilos	Cubic Feet	Cubic Meters	Width		Depth		Height	
	Inches	mm	Inches	mm	Inches	mm	Inches	mm	Inches	mm
COH-ES	300	136	20.6	0.6	35.5	902	34.5	877	29.0	737

COH-ED Double *Shipped in two cartons as per above specifications*

POWER SUPPLY

Model	KW	Voltage	Phase	Amps			Fan — 50 HZ		Fan — 60 HZ	
				Line 1	Line 2	Line 3	RPM-low	RPM-high	RPM-low	RPM-high
				COH-ES	9.5	208	3	29.0	29.0	25.0
	9.5	220-240	3	27.6	27.6	23.6	825	1425	1140	1,725
	9.5	208	1	47.3	47.3	—	825	1425	1140	1,725
	9.5	220-240	1	44.8	44.8	—	825	1425	1140	1,725

Each oven requires separate electrical connections

MINIMUM CLEARANCES

	Vent Hood		Direct Venting	
	Inches	mm	Inches	mm
Right	1	25	NA	NA
Left	1	25	NA	NA
Rear	1	25	NA	NA