



FULL-SIZE ELECTRIC CONVECTION OVENS



Model COB-ES
with optional casters

SPECIFICATIONS

Full-size electric, forced air, single and double deck convection type oven. Standard specifications include 10.5 KW per deck, a two-speed fan with cool down and our patented wheel-within-a-wheel enhanced air flow system powered by an energy saving 1/4 HP air cooled fan motor.

Door interlock switch automatically turns the fan and heating elements off when the right oven door is open. A manual rotary switch will turn the fan on when the door is open for quick cool-down. The 60 minute timer has a continuous ring alarm with manual shut-off. The indicator light glows when the heating elements are on.

The oven interior measures 29" wide (737mm) by 20" high (508mm) by 22 1/4" deep (567mm). The cooking chamber is porcelain enamel over heavy gauge steel with removable 11-position rack guides with 1 5/8" spacing (41mm) and 5 heavy-duty adjustable chrome-plated racks.

The oven exterior measures 38 1/8" wide (968mm) by 38" deep without handles (963mm) and 41 15/16" deep with handles (1065mm) by 26 7/8" (683mm) high. Front, top, sides and trim are constructed with stainless steel. Single oven legs are 31 3/8" tall (797mm) with casters and 27 5/8" (702mm) with adjustable bullet feet and finished with Durable Black Powder Coating.

Dual doors are 60/40 split-type with double-pane thermal glass, independent operation, stainless steel seals and double mounted "Cool Touch" handles. Doors are fabricated with stainless steel inside-and-out, and fully insulated with 2" of industrial grade

Job _____ Item # _____

ELECTRIC CONVECTION OVENS

- Model COB-ES Single
- Model COB-ED Double

STANDARD FEATURES

- Energy efficient 10.5 KW oven direct forced air heat system
- 208v or 220v-240v, 60hz, 1 or 3 phase
- Electronic temperature control
- Double-pane thermal glass door windows
- Oven lights
- 60-Minute continuous ring timer with manual shut-off
- 150°F (65°C) to 550°F (288°C) temperature range
- 1/4 HP air-cooled two-speed fan motor
- Cool down fan mode
- Elements-on and temperature-ready indicator lights
- Porcelain enamel oven interior with cove corners
- 11-Position removable rack guide with 1 5/8" spacing
- 5 Heavy-duty, positive-stop, chrome-plated wire racks
- Stainless steel front, top & sides
- Black Powder Coated legs with adjustable bullet feet
- Stainless steel, 60/40 split independent operation doors, with dual mounted handles
- Stainless steel door seals
- Stacking kit for double ovens
- Front mounted, hinged control panel for easy service access
- Heavy-duty industrial grade insulation in top, sides, back & doors
- Limited 1-year parts, labor & door warranty

OPTIONS & ACCESSORIES

- Open rack stand with rack supports and solid stainless steel undershelf (wire racks sold separately)
- Stainless steel undershelf (single ovens only)
- Additional oven racks
- Heavy-duty caster set, two with caster locks
- Perforated rear panel - field installation only
- International voltages, 50hz
- Stainless steel legs with or without casters

CERTIFICATIONS



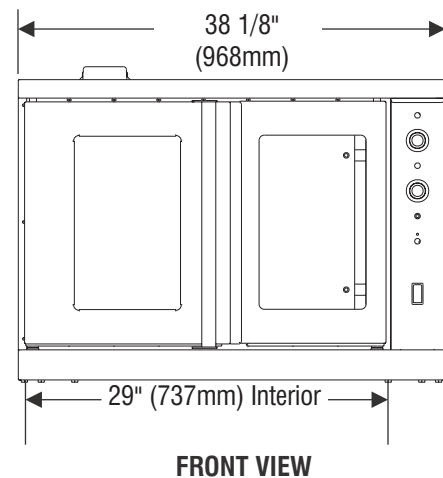
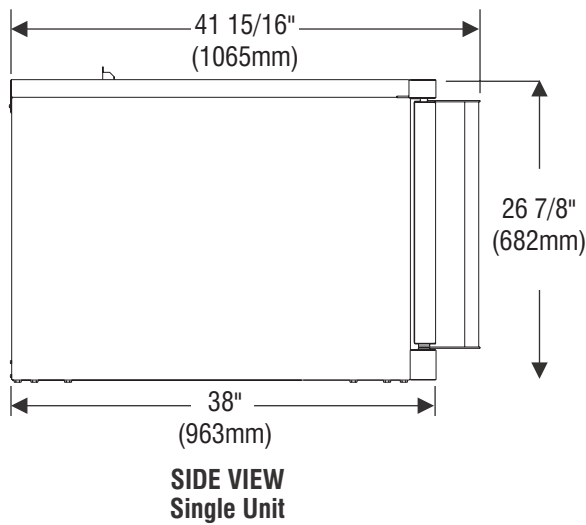
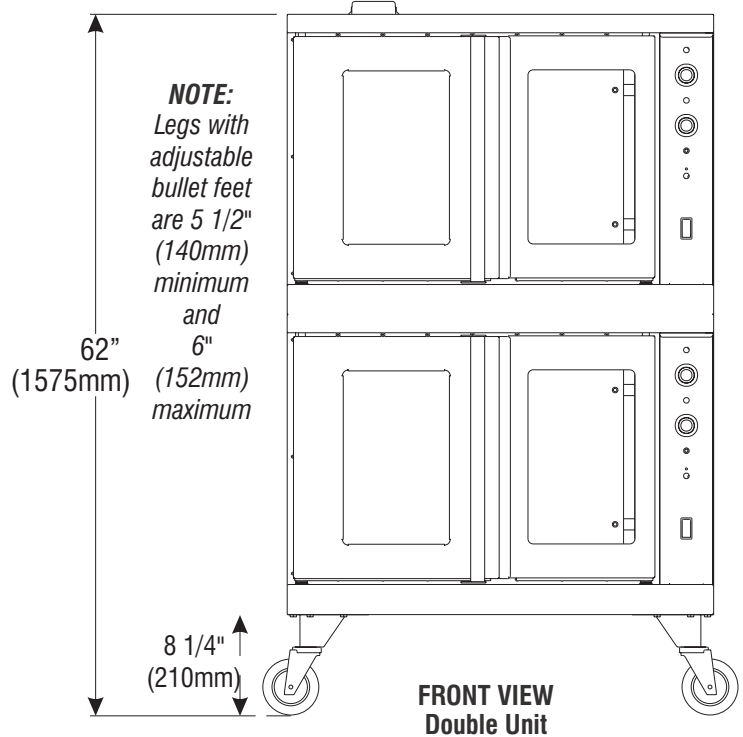
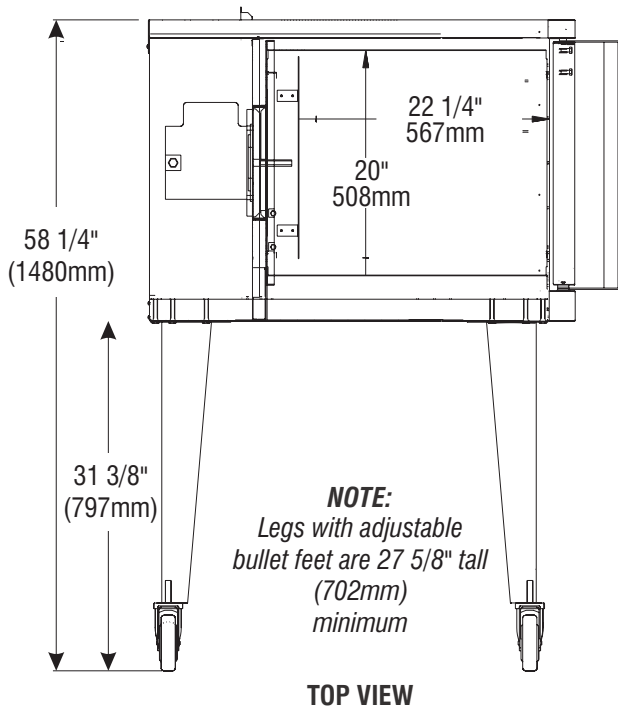

ALL DIMENSIONS NOMINAL

Continuous product improvement is a policy of BKI. Therefore, specifications and design are subject to change without notice.

Model	Shipping Weight		Carton Size		Carton Dimensions					
	Lbs.	Kilos	Cubic Feet	Cubic Meters	Width		Depth		Height	
	Inches	mm	Inches	mm	Inches	mm	Inches	mm	Inches	mm
COB-ES	514	234	45.93	1.29	43	1092	48 1/4	1226	34	864
COB-ED	DOUBLE Shipped in two cartons as per above specifications									

Model	KW	Voltage	Phase	Amps			Fan — 50 HZ		Fan — 60 HZ	
				Line 1	Line 2	Line 3	RPM-low	RPM-high	RPM-low	RPM-high
				COB-ES	10.5	208	3	30	30	28
	10.5	220-240	3	26	26	24	748	1425	850	1725
	10.5	208	1	48	48	—	748	1425	850	1725
	10.5	220-240	1	44	44	—	748	1425	850	1725

Each oven requires separate electrical connections

	Vent Hood		Direct Venting	
	Inches	mm	Inches	mm
Right	1	25	NA	NA
Left	1	25	NA	NA
Rear	3	76	NA	NA

Suitable for installation on combustible floors when installed on factory supplied legs or casters