



FULL-SIZE GAS CONVECTION OVENS

Job _____ Item # _____

GAS CONVECTION OVENS



Model CO1-GS Single

Model CO1-GD Double



Model CO1-GS with optional casters

STANDARD FEATURES

- Energy efficient 60,000 BTU/HR oven indirect/direct forced air combination heat system
- Natural or propane gas, 120v or 208v-240v 60hz
- Electronic temperature control
- Electronic hot surface ignition system with safety shut-off
- Double-pane thermal glass door windows
- Oven lights
- 60-Minute continuous ring timer with manual shut-off
- 150°F (65°C) to 550°F (285°C) temperature range
- Energy efficient 1/4 HP two-speed fan motor
- Cool down fan mode
- Burner-on and temperature-ready indicator lights
- Porcelain enamel oven interior
- 11-Position removable rack guides with 1 5/8" spacing
- 5 Heavy-duty, positive-stop, chrome-plated wire racks
- Stainless steel front, top & sides
- 7-Gauge steel legs with durable Baker Tone finish
- Stainless steel, 55/45 split synchronized doors, with single left mounted handle
- Stainless steel door seals
- Front mounted, hinged control panel for easy service access
- 1/8" Welded angle iron frame construction
- Aluminized steel combustion chamber — flue included
- Heavy-duty industrial grade insulation in top, sides, back & doors
- Removable tube burners
- Front accessible manual gas shut-off valve

SPECIFICATIONS

Gas heated, forced air convection type oven. Standard specifications include 60,000 BTU/HR per cavity, 3/4" NPT rear gas connection, two speed fan powered by an energy saving 1/4 HP hi-low fan motor with a unique 900 RPM low speed setting, and a 4-second cycle hot surface ignition system. 150° F (65°C) to 550° F (285°C) temperature range.

Door interlock switch automatically turns the fan and ignition off when the oven door is open. A manual rotary control will turn the fan on when the door is open for quick cool-down. The 60-minute timer has a continuous ring with manual shut-off. An indicator light glows when the burner is on.

The oven interior measures 29" wide (737mm) by 20" high (508mm) by 22 1/2" deep (572mm) with a porcelain enamel finish over heavy gauge steel featuring a full sized cooking chamber with removable 11-position rack guide with 1 5/8" spacing and 5 heavy duty adjustable chrome-plated racks.

The oven exterior measures 39 3/8" wide (1000mm) by 38 3/8" deep (975) by 33 3/8" high (848mm). Front, top and sides are constructed with stainless steel. Single oven legs are 30" tall (6" for double), 7-gauge steel and finished with durable Baker Tone finish.

Dual doors are 55/45 split-type with double-pane thermal glass, synchronized operation, stainless steel seals and a single left mounted "Cool Touch" handle. Doors are fabricated with stainless steel inside-and-out, and fully insulated with 2" of industrial grade insulation.

Limited 2 year part & labor and 5 year door warranty.

OPTIONS & ACCESSORIES

- Steam injection with front panel controls
- Computerized programmable controls with LED display for integrated use of Cook & Hold, multi function cooking, fan speed, fan cycle and steam injection functions
- Open rack stand with rack supports
- 30" Stainless steel legs with undershelf
- Single connection external gas manifolds for double decks
- Heavy-duty caster set, two with caster locks
- 48" Quick-disconnect gas hoses with restraining cables
- Stainless steel perforated rear panel
- Solid Doors
- Correctional Facility package
- International voltages, 50hz

CERTIFICATIONS



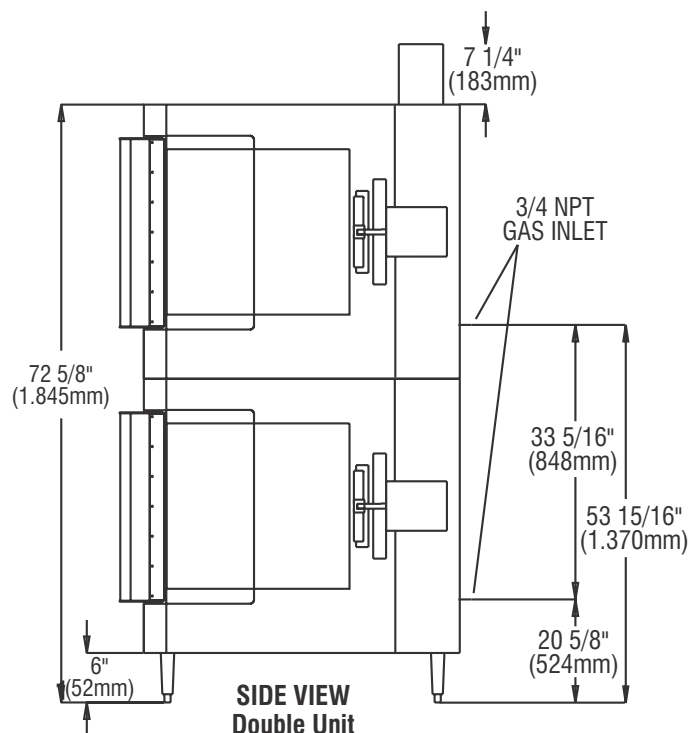
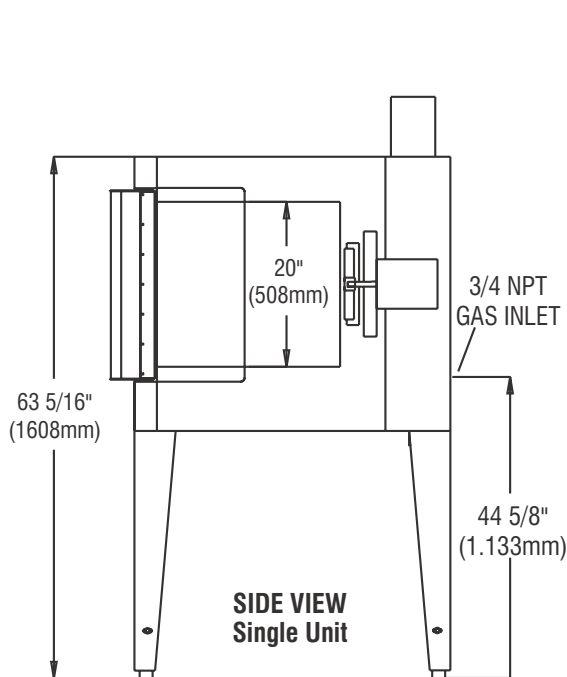
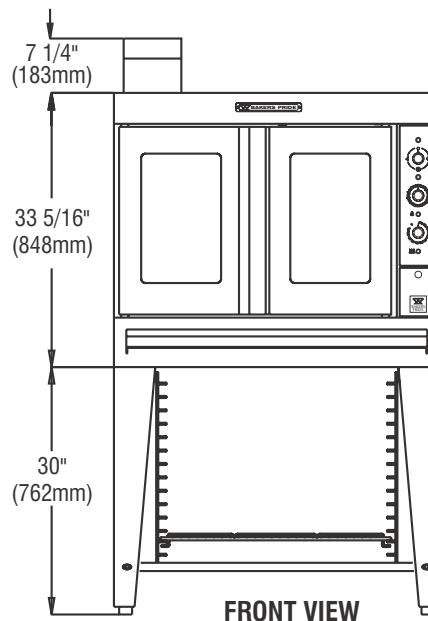
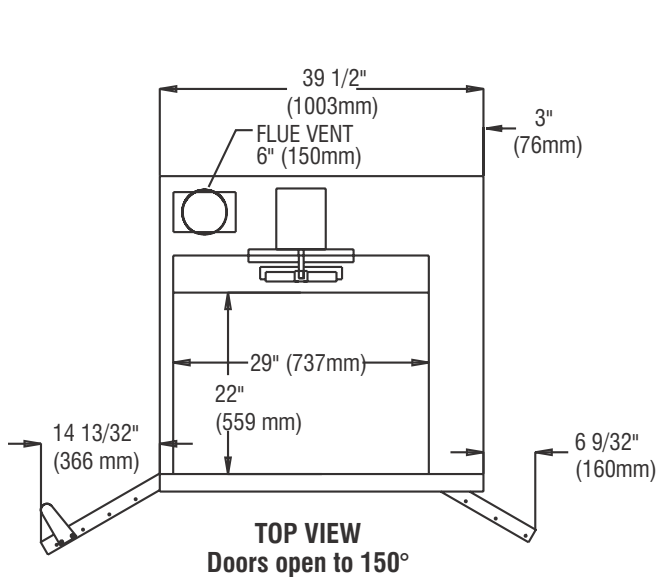

ALL DIMENSIONS NOMINAL

Continuous product improvement is a policy of BKI. Therefore, specifications and design are subject to change without notice.

SHIPPING INFORMATION

Model	Shipping Weight		Carton Size		Carton Dimensions					
	Lbs.	Kilos	Cubic Feet	Cubic Meters	Width		Depth		Height	
	Inches	MM	Inches	MM	Inches	MM	Inches	MM	Inches	MM
CO1-GS	660	349	43.5	1.23	43.5	1105	46.0	1168	37.5	952
CO1-GD	Shipped in two cartons as per above specifications									

POWER SUPPLY

Model	BTUH	KW	HZ	Voltage 1Ø	Amps	Wire	Phase	RPM-low	RPM-high
CO1-GS	60,000	17.58	60	115	7.5	2	1	900	1,725
CO1-GS	60,000	17.58	60	208/240	4	2	1	1,140	1,725
CO1-GS	60,000	17.58	50	230	4	2	1	950	1,425
CO1-GD	120,000	35.16	60	115	2 x 7.5	2	1	900	1,725
CO1-GD	120,000	35.16	60	208/240	2 x 4	2	1	1,140	1,725
CO1-GD	120,000	35.16	50	230	2 x 4	2	1	950	1,425

GAS SUPPLY — 3/4" NPT rear connection

Gas Type	Manifold Pressure		Inlet Pressure	
	WC	Mbar	Inches	Mbar
Natural	3.5"	9 min	7"	17.5 min
Propane			11"	27.5 min
	10"	25 max	13"	32.5 max

Separate gas connections or external manifold required for stacked ovens

MINIMUM CLEARANCES

	Vent Hood		Direct Venting	
	Inches	MM	Inches	MM
Right	1	25	1	25
Left	1	25	3	76
Rear	3	76	3	76

Suitable for installation on combustible floors when installed on factory supplied legs or casters