



# FULL-SIZE ELECTRIC CONVECTION OVENS

Job \_\_\_\_\_ Item # \_\_\_\_\_

## ELECTRIC CONVECTION OVENS

- Model CO1-ES Single
- Model CO1-ED Double



**Model CO1-ES  
with optional casters**

### STANDARD FEATURES

- Energy efficient 10.5 KW oven direct forced air heat system
- 208v or 220v-240v, 60hz or 50hz, 1Ø or 3Ø
- Electronic temperature control
- Double-pane thermal glass door windows
- Oven lights
- 60-Minute timer with continuous ring alarm & manual shut-off
- 150°F (65°C) to 550°F (285°C) temperature range
- 1/4 HP air-cooled two-speed hi-lo fan motor
- Cool down fan mode
- Elements-on and temperature-ready indicator lights
- Porcelain enamel oven interior
- 11-Position removable rack guide with 1 5/8" spacing
- 5 Heavy-duty, positive-stop, chrome-plated wire racks
- Stainless steel front, top & sides
- 7-Gauge steel legs with durable Baker Tone finish
- Stainless steel, 55/45 split synchronized doors, with single left mounted handle
- Stainless steel door seals
- Front mounted, hinged control panel for easy service access
- 1/8" Welded angle iron frame construction
- Heavy-duty industrial grade insulation in top, sides, back & doors
- 2-year parts & labor warranty and 5-year warranty on doors

### SPECIFICATIONS

Full-size electric, forced air, single and double deck convection type oven. Standard specifications include 10.5 KW per deck and a patented two speed wheel-within-a-wheel enhanced air flow system powered by an energy saving 1/4 HP air cooled fan motor.

Door interlock switch automatically turns the fan and heating elements off when the oven door is open. A manual rotary switch will turn the fan on when the door is open for quick cool-down. The 60-minute timer has a continuous ring alarm with manual shut-off. An indicator light glows when the heating elements are on.

The oven interior measures 29" wide (737mm) by 20" high (508mm) by 22 1/2" deep (572mm). The cooking chamber is porcelain enamel over heavy gauge steel with removable 11-position rack guides with 1 5/8" spacing (41mm) and 5 heavy-duty adjustable chrome-plated racks.

The oven exterior measures 39 3/8" wide (1003mm) by 38 1/2" deep (978mm) by 33 5/16" high (846mm). Front, top and sides and trim are constructed with stainless steel. Single oven legs are 30" tall (762mm) (6" [152mm] for double), 7-gauge steel and finished with durable Baker Tone finish.

Dual doors are 55/45 split-type with double-pane thermal glass, synchronized operation, stainless steel seals and a single left mounted "Cool Touch" handle. Doors are fabricated with stainless steel inside-and-out, and fully insulated with 2" of industrial grade insulation.

### OPTIONS & ACCESSORIES

- Steam/moisture injection with front panel controls
- Computerized programmable controls with LED display for integrated use of Cook & Hold, fan speed, pulse fan mode, and manual override functions
- Open rack stand with rack supports
- 30" Stainless steel legs with undershelf
- Additional oven racks
- Heavy-duty caster set, two with caster locks
- Perforated rear panel
- Solid doors - N/C
- Correctional Facility package
- International voltages, 480V
- Stainless steel interior

### CERTIFICATIONS



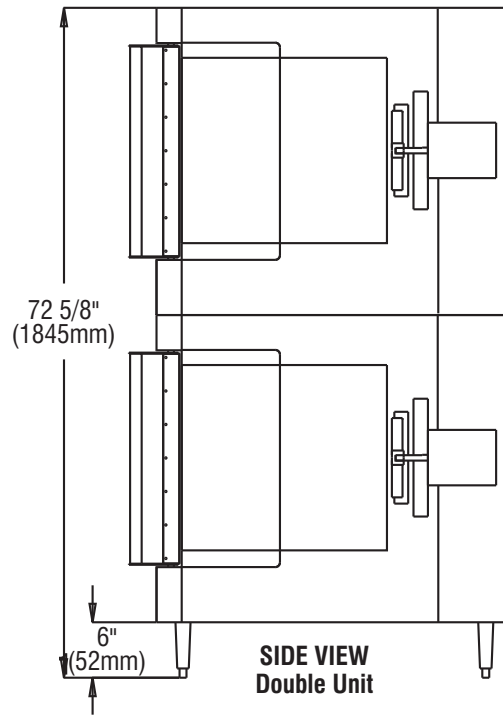
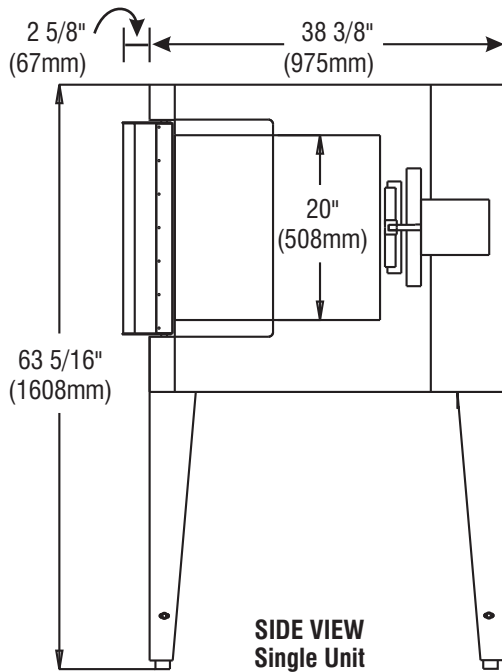
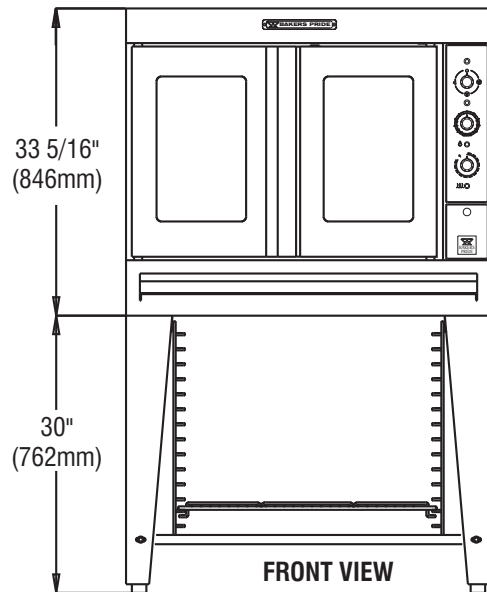
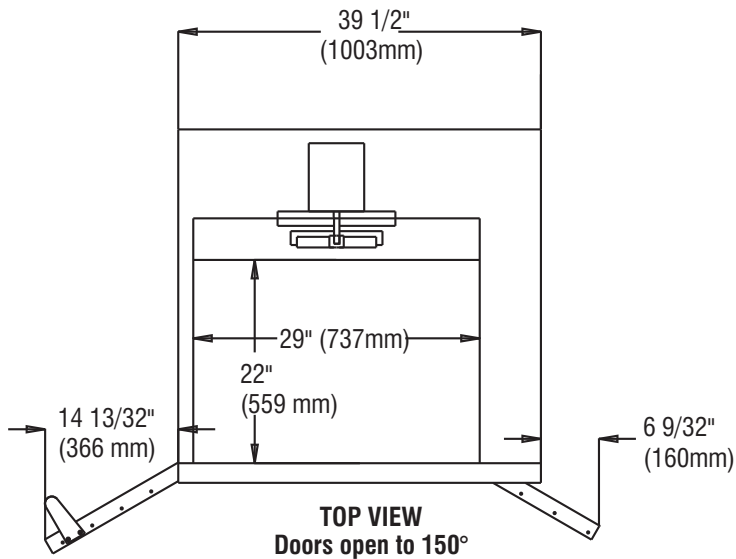

ALL DIMENSIONS NOMINAL

Continuous product improvement is a policy of BKI. Therefore, specifications and design are subject to change without notice.

**SHIPPING INFORMATION**

Model	Shipping Weight		Carton Size		Carton Dimensions					
	Lbs.	Kilos	Cubic Feet	Cubic Meters	Width		Depth		Height	
	Inches	mm	Inches	mm	Inches	mm	Inches	mm	Inches	mm
CO1-ES	640	291	47.8	1.26	45	1143	44 1/2	1130	41 3/4	1048
CO1-ED Double	<i>Shipped in two cartons as per above specifications</i>									

**POWER SUPPLY**

Model	KW	Voltage	Phase	Amps			Fan — 50 HZ		Fan — 60 HZ	
				Line 1	Line 2	Line 3	RPM-low	RPM-high	RPM-low	RPM-high
				CO1-ES	10.5	208	3	31.8	31.8	27.8
	10.5	220-240	3	30.2	30.2	26.2	825	1425	1140	1,725
	10.5	208	1	52	52	—	825	1425	1140	1,725
	10.5	220-240	1	49.5	49.5	—	825	1425	1140	1,725

Each oven requires separate electrical connections

**MINIMUM CLEARANCES**

	Vent Hood		Direct Venting	
	Inches	mm	Inches	mm
Right	1	25	NA	NA
Left	1	25	NA	NA
Rear	3	76	NA	NA

*Suitable for installation on combustible floors when installed on factory supplied legs or casters*