

BKI

COMBIKING 6-PAN COMBINATION OVENS



Model C1.06
with optional stand with runners

SPECIFICATIONS

CombiKING combination ovens are available in eight different sizes and each size is available in four unique models: C, CPE, K and KPE. All are standard with single door/solid back while pass-thru, dual-doors are optional. Model 1.20 is available as a roll-in.

All models may be used as a convection oven or as a steamer, or both together, and feature an operator-controlled 9-speed, reversible fan, temperature probe, 86°-482°F (30°-250°C) temperature range, up to 572°F (300°C) pre-heat temperature, all stainless steel interior and exterior, reversible, curved-glass door, 2-step safety handle, hose & spray gun, 3/4" water connection with 1/2" drain.

C MODELS feature steam injection, 2-step Combi steaming, 10 programs each 3-process steps, semi-automatic cleaning system, cook & hold function and digital display with clock/timer functions.

CPE MODELS have all the features of the C models PLUS precise humidity control (0 to 100%), 200 program capacity each with up to 10 process steps, 65 built-in, starter recipes, USB port, Delta-T cooking, HACCP system and automatic diagnostic service system.

K MODELS have all the features of the C models PLUS a built-in steam generator that produces 212°F (100°C) pure, dry steam with hygienic boiler flushing system.

KPE MODELS have all the features of the CPE models PLUS a built-in steam generator which produces 212°F (100°C) pure, dry steam with hygienic boiler flushing system.

1.06 Models have a 6-pan capacity: 12"x20" or 13"x18" or GM pans and measures 35 7/16" (900mm) wide by 31 5/16" (795mm) tall without stand by 32 5/16" (829mm) deep.

Limited 1 year parts, 1 year labor warranty.

Job _____ Item # _____

COMBINATION OVENS



<input type="checkbox"/> Model C 1.06	Steam Injection	10 Programs
<input type="checkbox"/> Model CPE 1.06	Steam Injection	200 Programs
<input type="checkbox"/> Model K 1.06	Steam Boiler	10 Programs
<input type="checkbox"/> Model KPE 1.06	Steam Boiler	200 Programs

STANDARD FEATURES

- 6-Pan capacity 12"x20" or 13"x18" or GM
- 86°-482°F (30°-250°C) temperature range
- Up to 572°F (300°C) pre-heat temperature
- Internal temperature probe
- 9-Speed, reversible fan
- All stainless steel interior & exterior
- Hose with spray gun for cleaning
- Curved-glass, reversible door (left-hand hinge standard)
- 2-Step safety handle
- 3/4" Water connection and 1/2" drain
- External water filtration system
- C and K Models feature steam injection, 10 programs each with 3 process steps and semi-automatic cleaning system
- CPE and KPE Models feature a built-in steam boiler, 200 programs each with 10 process steps and USB port for data, software and recipe transfer
- Limited 1 year parts - 1 year labor warranty

OPTIONS & ACCESSORIES

- Pass-thru design (doors on both sides) 1.06, 1.10, 1.16 & 1.20
- Stacking kit (model 1.06 may be stacked on another 1.06 or on a model 1.10)
- Stainless steel stand without runners (standard on 1.16, 1.20 & 1.20 roll-in)
- Stainless steel stand with runners (not available on 1.16, 1.20 & 1.20 roll-in)
- 2-Piece rack (standard with 1.06, 1.20 & 1.20 roll-in)
- Cassette rack (standard with 1.06, 1.08, 1.10 & 1.12)
- Trolley for cassette racks
- Roll-in trolley for 1.20RI
- Replacement water filters
- Fat separation system
- Integrated extraction hood
- Fully automatic cleaning system
- Racks for steak searing or Shish-Ka-Bobs

CERTIFICATIONS



BKI North America
2812 Grandview Drive • Simpsonville, SC 29680-0400 USA
Phone: 864.963.3471 • 800.972.6887 • fax: 864.963.5316
www.BKIideas.com

BKI Europe
Theale Technology Centre
Station Road • Theale • Reading • West Berkshire • RG74AA
Telephone: 0870 9904242 • fax: 08709904243



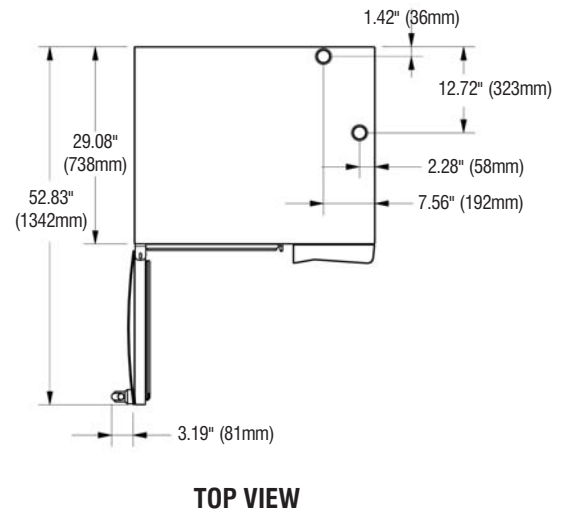
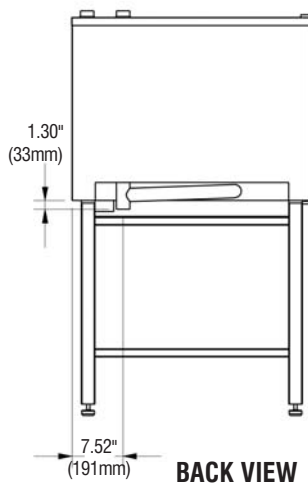
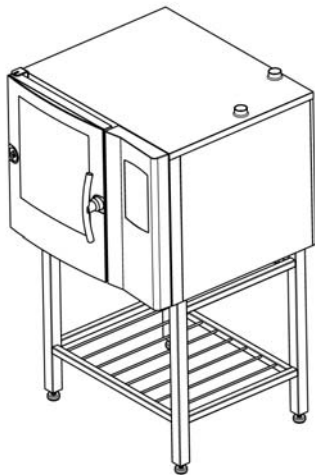
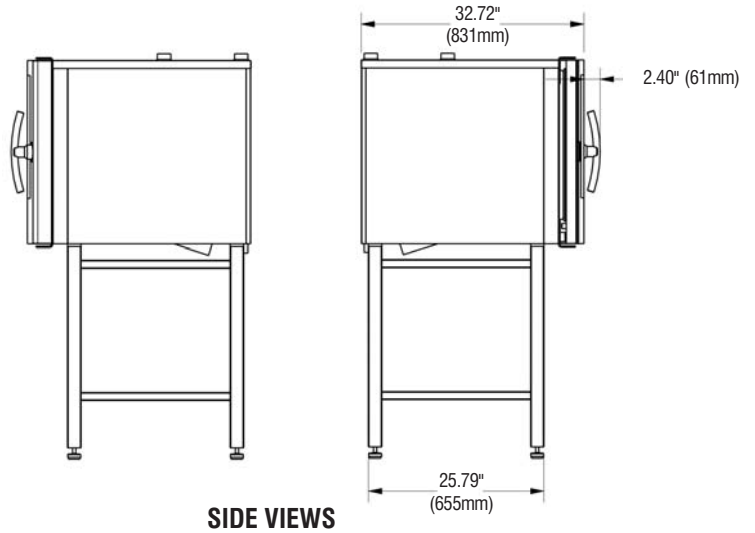
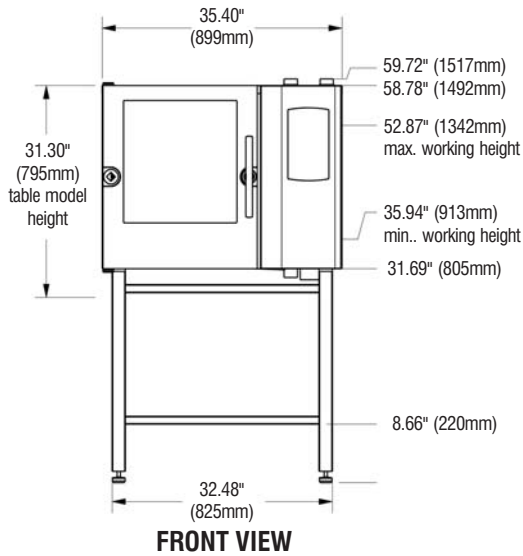

ALL DIMENSIONS NOMINAL

Continuous product improvement is a policy of BKI/BEVLES. Therefore, specifications and design are subject to change without notice.

SHIPPING INFORMATION										
Model	Carton Size		Carton Dimensions				Shipping Weight			
	Cubic Feet	Cubic Meters	Width		Depth		Height		Lbs	Kilos
	Inches	mm	Inches	mm	Inches	mm	Inches	mm		
1.06	33.5	.93	38	965	39	991	39	991	231	105

CAPACITY				
Model	12"x20"	GM	13"x18"	18"x26"
1.06	6	6	6	—

POWER SUPPLY				
Models	Volts	KW	Amps	Phase
1.06	208	9	25	3

MINIMUM CLEARANCES		
	Inches	mm
Right	3"	70
Left	0"	0
Rear	2"	50