

# BDL Series

Yesterday's Reliability Meeting Today's Demands



BDL-11



BDL-13



Wheels standard

by **Yamato**

# MECHANICAL SCALE

## BDL Series

### 13" and 11" Dials

### Rugged Construction

#### Application

With a stable easy to read indicator and rugged construction, the BDL scales are ideally suited for industrial and heavy commercial use.

#### Features

- ◆ Large, convenient platform
- ◆ Easy to use
- ◆ Instant readings
  - Double air dashpots (13" only)
- ◆ Accurate
  - Fine point indicator
  - Temperature compensated spring mechanism
- ◆ Rugged, durable construction
  - Heavy duty cast iron base
- ◆ Wheels for easy portability (13" only)
- ◆ Locking lever to prevent damage to weighing mechanism during transport
- ◆ Versatile

#### Specifications

Model	BDL-13 and BDL-11	
	<b>BDL-13</b>	
	50D	50 lb x 0.1 lb
	25M	25 kg x 0.05 kg
	50M	50 kg x 0.1 kg
	100M	100 kg x 0.2 kg
<b>Capacity and Divisions</b>	125PK	125 lb x 0.25 lb 56 kg x 0.1 kg
	250PK	250 lb x 0.5 lb 112 kg x 0.2 kg
		<b>BDL-11</b>
	60PK	60 lb x 2 oz 27 kg x 0.05 kg
	100PK	100 lb x 4 oz 45 kg x 0.1 kg
	200PK	200 lb x 8 oz 90 kg x 0.2 kg
<b>Weighing System</b>	Dual Springs	
<b>Platform</b>	BDL-13	13.5 x 20.5 (349 x 528)
	BDL-11	10.5 x 15.0 (267 x 381)
<b>Indicator</b>	Dial Chart with Fine Point Indicator	
<b>Operating Temperature</b>	14 °F ~ 104 °F (-10 C ~ 40 C)	
<b>Shipping Weight</b>	BDL-13	102 lb (46.3 kg)
	BDL-11	49 lb (22.2 kg)

All dimensions are approximate. Dimensions are given in inches (millimeters).

#### Dimensions

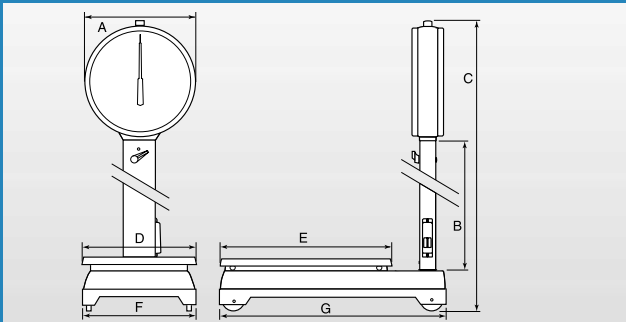

	11" Models	13" Models
	standard	standard
A	11	13
B	19.9	19.1
C	36.3	37.8
D	10.5	13.5
E	15.0	20.5
F	11.5	13.5
G	22.5	27.5

# Yamato

www.YamatoCorp.com

**Yamato Corporation**  
P.O. Box 15070  
Colorado Springs, CO 80935-5070  
U.S.A.  
Tel (719) 591-1500  
Fax (719) 591-1045

**Yamato Tech Corporation**  
#112-19425 Langley By-Pass  
Surrey, B.C. V3S 6K1  
Canada  
Tel (604) 533-2338  
Fax (604) 533-0827

YCO-1043-03-01 Printed in U.S.A.