



Model 641-21
Model 641-17
Model 641-14

Dough Roller

Key Features:

- Ideal for pizzas, tortillas, and pie crusts
- Quickly produces crusts of uniform thickness, automatically
- Perfect for applications where floor space is limited
- Easy to operate
- Available in a choice of 14", 17", or 21" widths
- USDA listed



The information contained herein is correct to the best of our knowledge. The recommendations or suggestions are made without guarantee or representation as to results.

Above specifications subject to change without notice.



Manufactured in the U.S.A.



Oliver Packaging & Equipment Company
(800) 253-3893 • (616) 356-2950 • www.oliverquality.com



Model 641-21
Model 641-17
Model 641-14

Dough Roller

SPECIFICATIONS:

Motor:

1/2 H.P., single phase, 60Hz, 115 VAC, 7.0 AMPS

1/2 H.P., single phase, 60Hz, 230 VAC, 3.5 AMPS

Also available: 1/2 H.P., single phase, 50 Hz, 220 VAC, 4.2 AMPS

Lubrication:

Permanently lubricated, sealed ball-bearings

Finish:

Stainless steel and corrosion resistant alloys throughout

21" model: 250 lbs. (113kg)

17" model: 240 lbs. (109kg)

14" model: 230 lbs. (104kg)

Height:

22" (914mm)

Depth:

33" (838mm)

Width:

21" model: 37" (914mm)

17" model: 33" (813mm)

14" model: 30" (737mm)

Optional:

Powder coated white stand with casters, height: 33" (838mm)

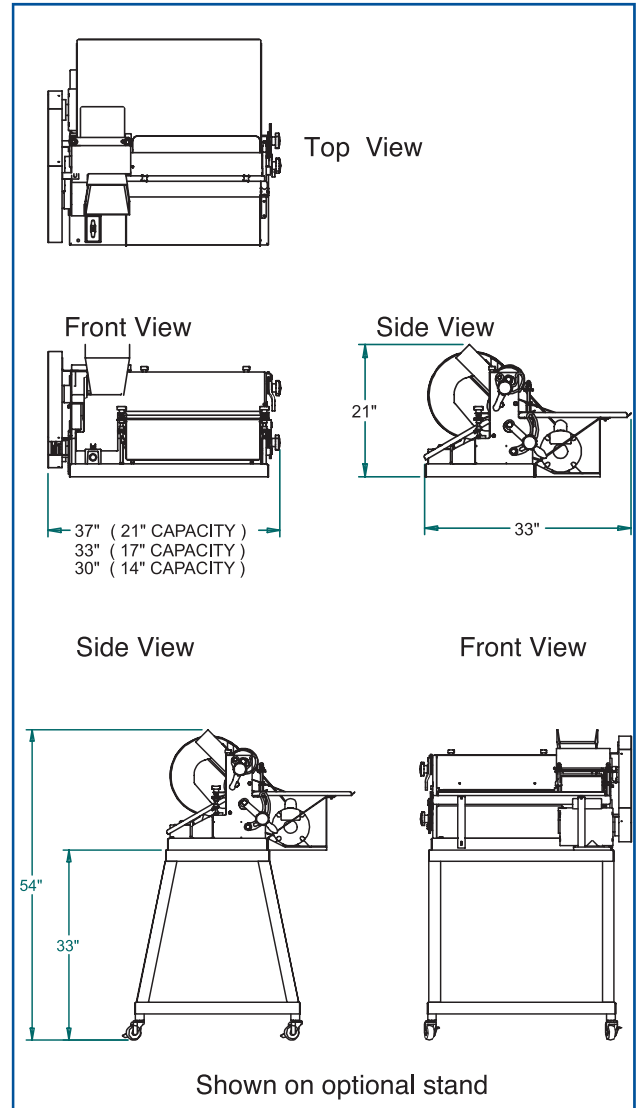

The information contained herein is correct to the best of our knowledge. The recommendations or suggestions are made without guarantee or representation as to results.

Above specifications subject to change without notice.

Manufactured in the U.S.A.



Oliver Packaging & Equipment Company
(800) 253-3893 • (616) 356-2950 • www.oliverquality.com