

**New Brunswick International, Inc.**

**MODEL 350 VK TC**



# MANUAL VERTICAL SLICING MACHINE

DESCRIPTION	/	BENEFIT
-------------	---	---------

• Gear driven motor, ½ HP		• Stress resistant and long lasting
• Blade with enhanced cutting section		• Precision cutting & minimizes waste
• Built in blade sharpener		• Easy to use; precise sharpening increases blade life
• Large plate with long stroke		• Increased cutting capacity for large items
• Wide Platform with smooth edges		• Easy Access for cleaning
• Easy to load product		• Consistent cut thickness for life of machine
• Enhanced knife cover		• Operator safety & cleaner working area
• Electrical protection IPX3		• Easy to clean, wash through design saves time and \$

Optional Features
-------------------

Teflon coated blade
Teflon coated slice thickness plate & blade cover
Removable aluminum meat press
Carriage with self-locking clamping device

Certifications
----------------

Dir. 98/37/CEE e 89/336/CEE
Dir. 73/23 CEE
EN 1974

BLADE SIZE
------------

350 MM BLADE / 13 ¾ INCH BLADE
--------------------------------

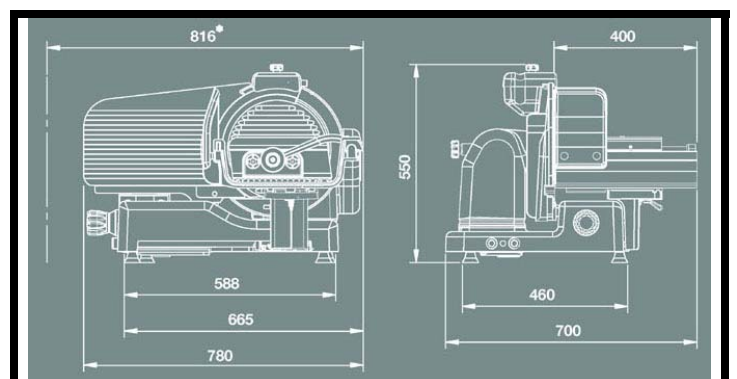

**NBI**   
**MANCONI**

New Brunswick International, Inc.  
76 Veronica Avenue  
Somerset, NJ 08873  
732-828-3633 or [www.nbidigi.com](http://www.nbidigi.com)