



Bagstar Bagger

Key Features:

- Countertop use or adjustable height table
- Complements Oliver 797 Chute-fed bread slicers
- Guides and funnels are adjustable without tools.
3 1/4" (83mm) to 6" (152mm) optional funnels available
- Inflates bread bag so that sliced bread can be quickly bagged

Accessories:

- Adjustable height table with locking casters
- Adjustable tilt tray for bread bagging or drop loading
- Hopper for drop loading
- Bag support to support bottom of bag when drop loading
- Bag tray extension for longer than average bags
- Small adjustable funnels 2 1/4" - 3 1/2"

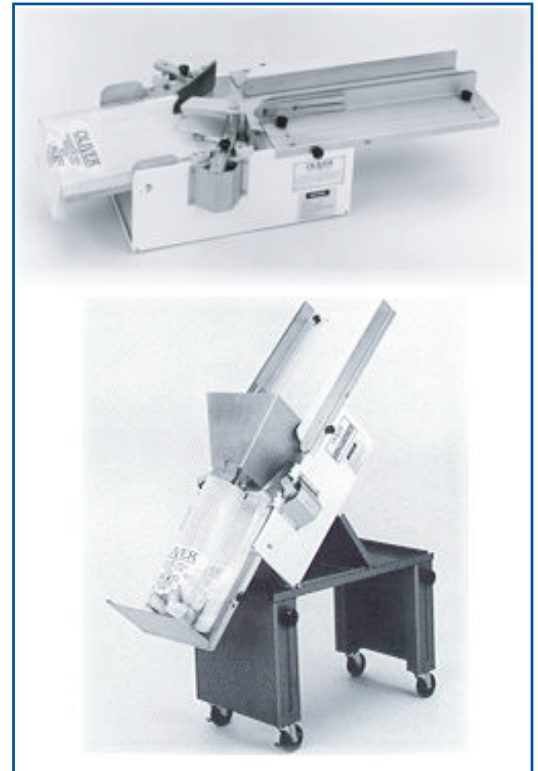



Bagstar Bagger

SPECIFICATIONS:

Electrics:

Single phase, 50 or 60 Hz, 115 VAC, 1.02 AMPS

Extra cost option: Single phase, 50 or 60 Hz, 230 VAC, .51 AMPS

Weight:

45lbs. (20kg)

Height:

9" (229mm)

Width:

16" minimum (406mm)

Length:

40 1/2" (1,029mm)

Maximum Product Width:

8 1/2" (216mm)

Adjustable Funnels:

Standard: 2 1/4" (57mm) to 3 1/2" (89mm)

Optional Funnels:

3 1/4" (83mm) to 6" (152mm)

Bag Width:

4" (102mm) to 13" (330mm)

Wicketed bags only

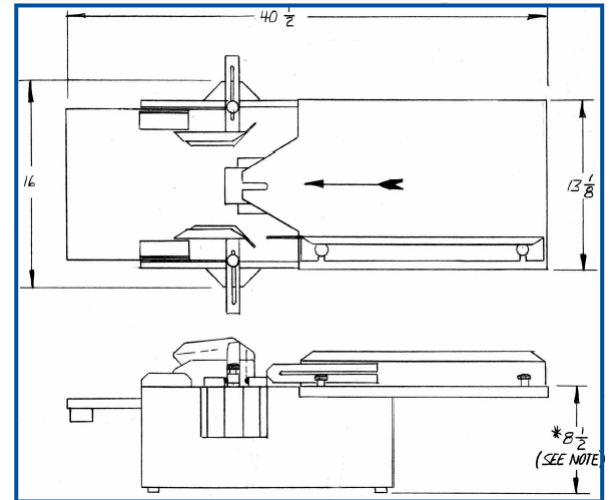

The information contained herein is correct to the best of our knowledge. The recommendations or suggestions are made without guarantee or representation as to results.

Above specifications subject to change without notice.

Manufactured in the U.S.A.



Oliver Packaging & Equipment Company
(800) 253-3893 • (616) 356-2950 • www.oliverquality.com